

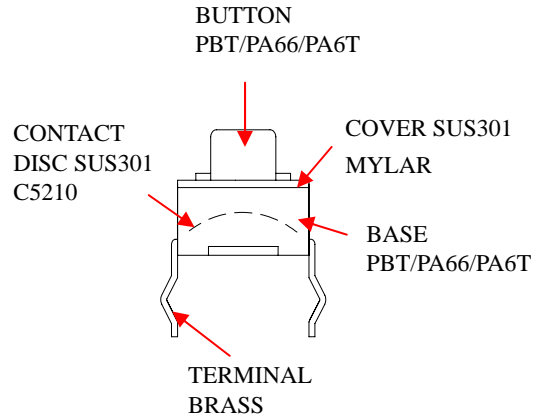

TS Series TACT SWITCH

MATERIALS



TS-01P(S)-***-6-*

DIMENSION DRAWING

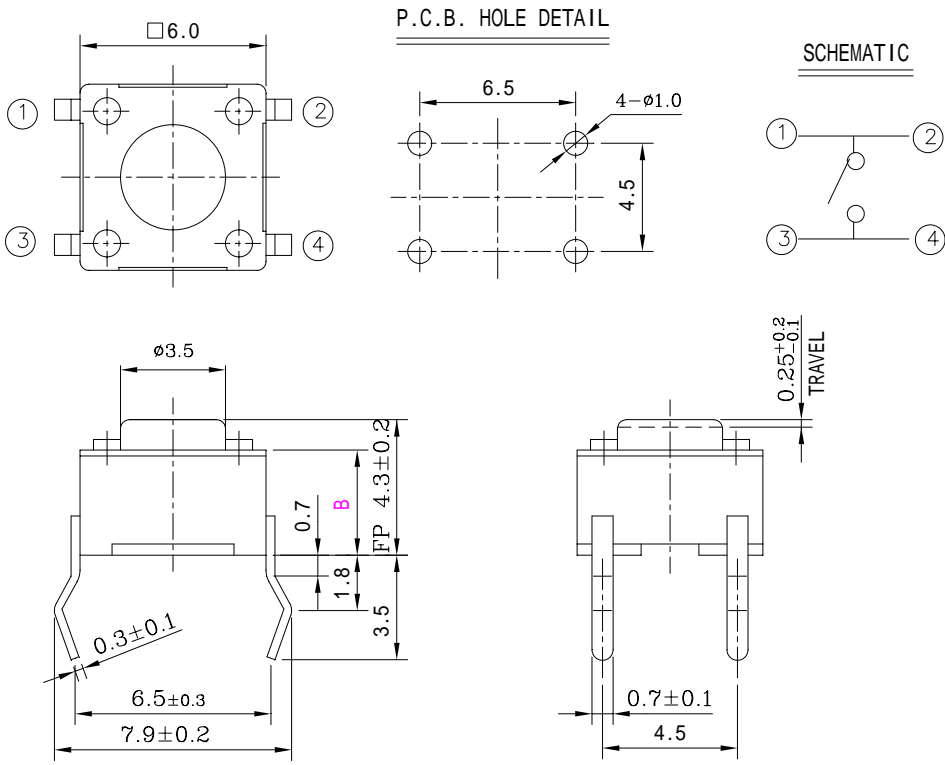

PART NO.	B =
TS-01P-***	3.20
TS-01PS-***	3.15

operating force	70 ± 20	100 ± 40	130 ± 40	160 ± 50	170 ± 50	250 ± 60
-----------------	---------	----------	----------	----------	----------	----------



TS Series TACT SWITCH

MATERIALS

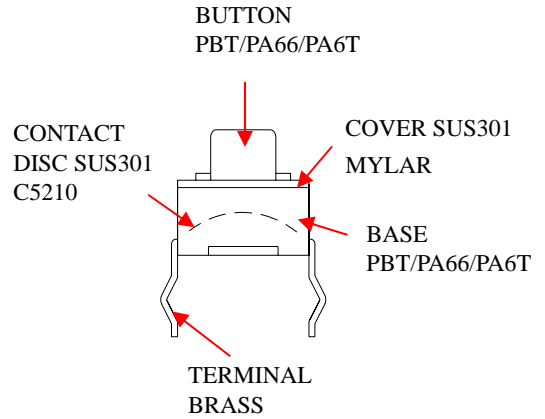

TS-**P(S)-***-*

DIMENSION DRAWING

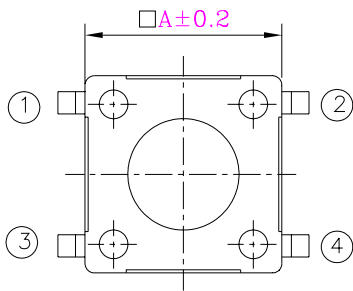

P.C.B. HOLE DETAIL

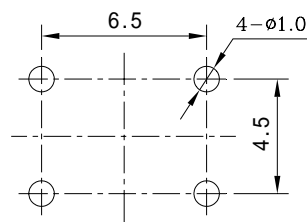

SCHEMATIC

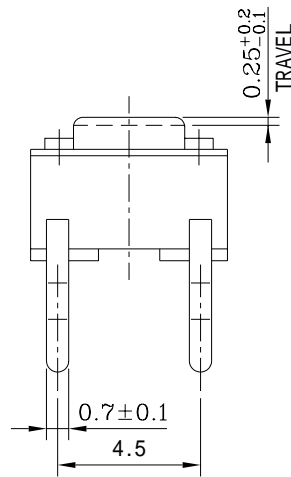
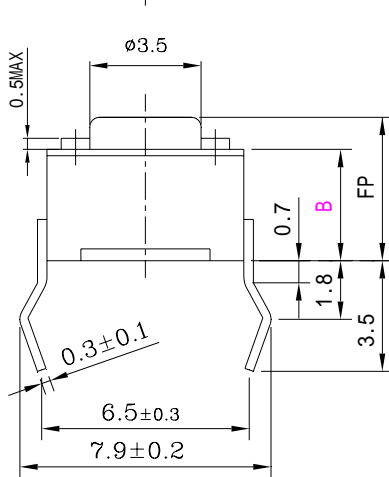
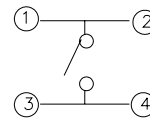

PART NO.	A
TS-XXP(S)-***-6-*	6.0
TS-XXP(S)-***	6.2

PART NO.	B
TS-XXP-***	3.55
TS-XXPS-***	3.5

operating force	70 ± 20	100 ± 40	130 ± 40	160 ± 50	170 ± 50	250 ± 60					
MODEL	TS-02P(S)	TS-03P(S)	TS-04P(S)	TS-07P(S)	TS-08P(S)	TS-09P(S)	TS-10P(S)	TS-11P(S)	TS-12P(S)	TS-13P(S)	TS-14P(S)
FP	5.0	7.0	9.5	6.3	12.0	7.9	13.0	5.7	4.2	17.0	5.5